

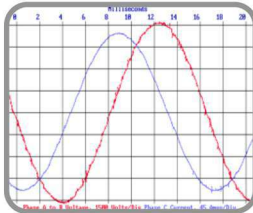

220kW-15000kW (air cooling), 7000kW-65000kW (liquid cooling)



- Voltage Class: 3kV, 3.3kV, 6kV, 6.6kV, 10kV, 11kV, 13.8KV, 18KV, etc.
- Power Range: 200kW – 65MW



- * Cell series multilevel PWM and almost sine waveform output, no need for extra du/dt filter.
- * Multiple-pulse rectifier (30 pulse or above), low input current harmonic distortion, no extra harmonic filter or power factor correction

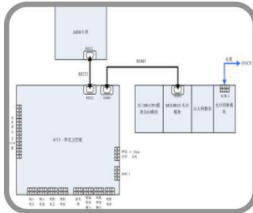

- * DSP+FPGA+ARM three core control platform
- * Core controller is a highly integrated single PCB of six-layer



- * Load: synchronous motor, asynchronous motor
- * Operation mode: speed regulation, soft starter, speed regulation & soft starter
- * High performance speed sensorless vector control/closed loop vector control

Cell Series Multilevel PWM Topology

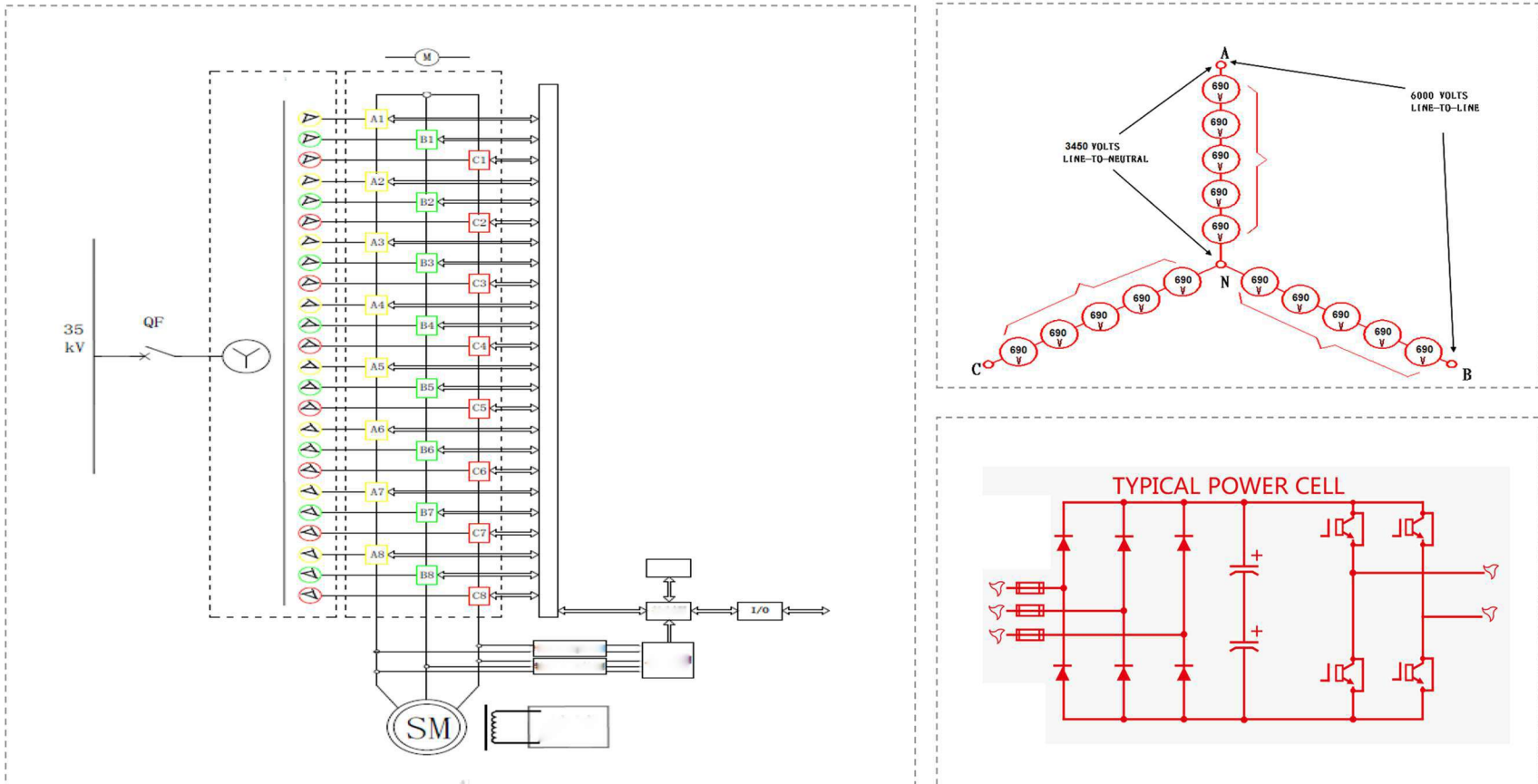

Power cell:
 5 Voltage level: 690V/750V/1350V/1550V/1750V;
 24 Current types: 50A ~ 2100A

Multi-level PWM principle

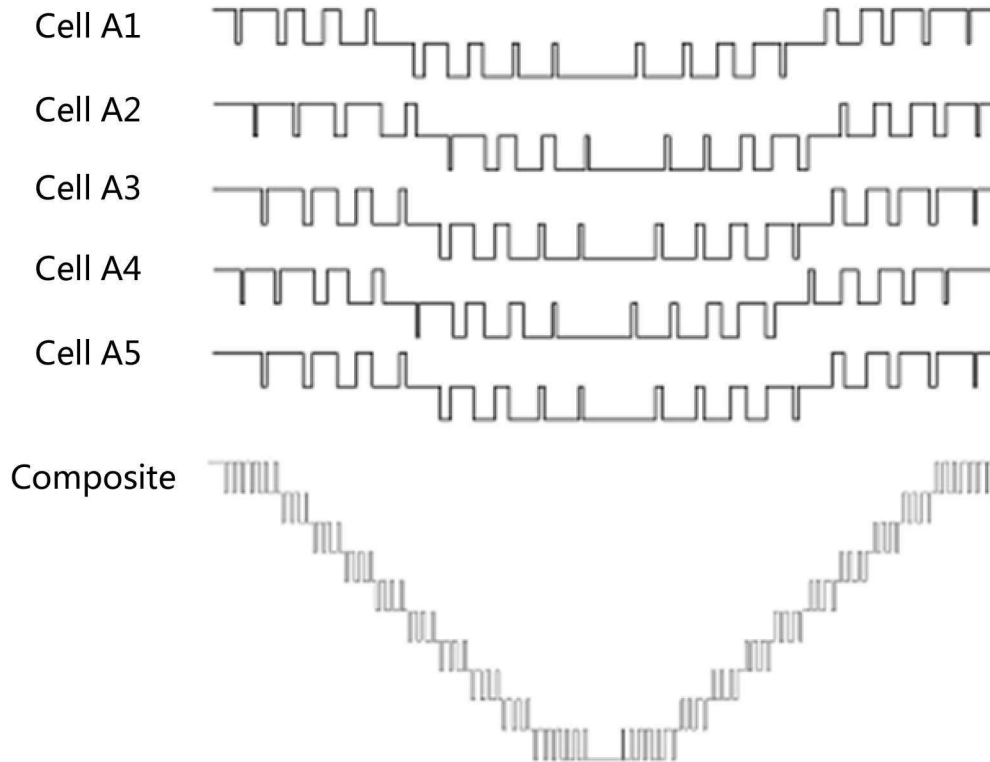

Traditional cell Bypass Technology

A4,A5,B4,B5,C4,C5
bypass after failure
of A4,A5

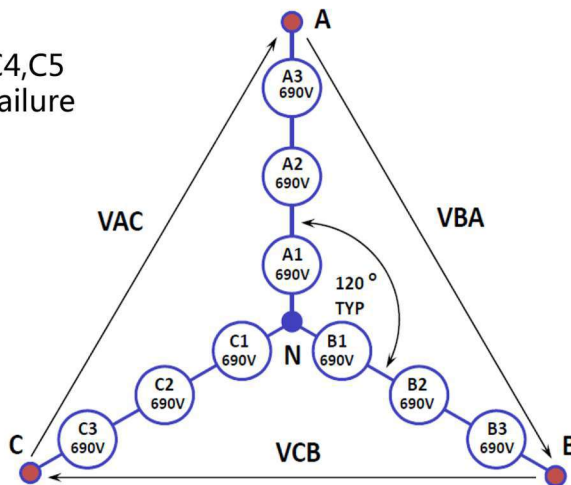

Voltage decline **40%**

Only A4,A5
bypass after
failure

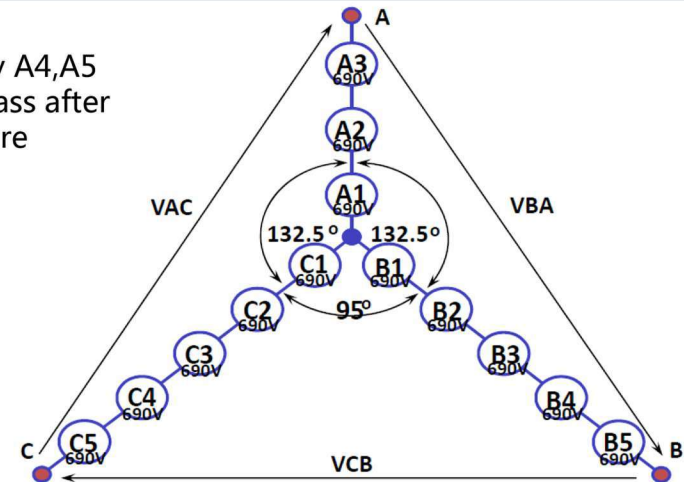

Adjusting phase angle , Voltage decline only **20%**

HOFFMANN Neutral Point Shift Technology

Synchronous Transfer between Grid & VFD

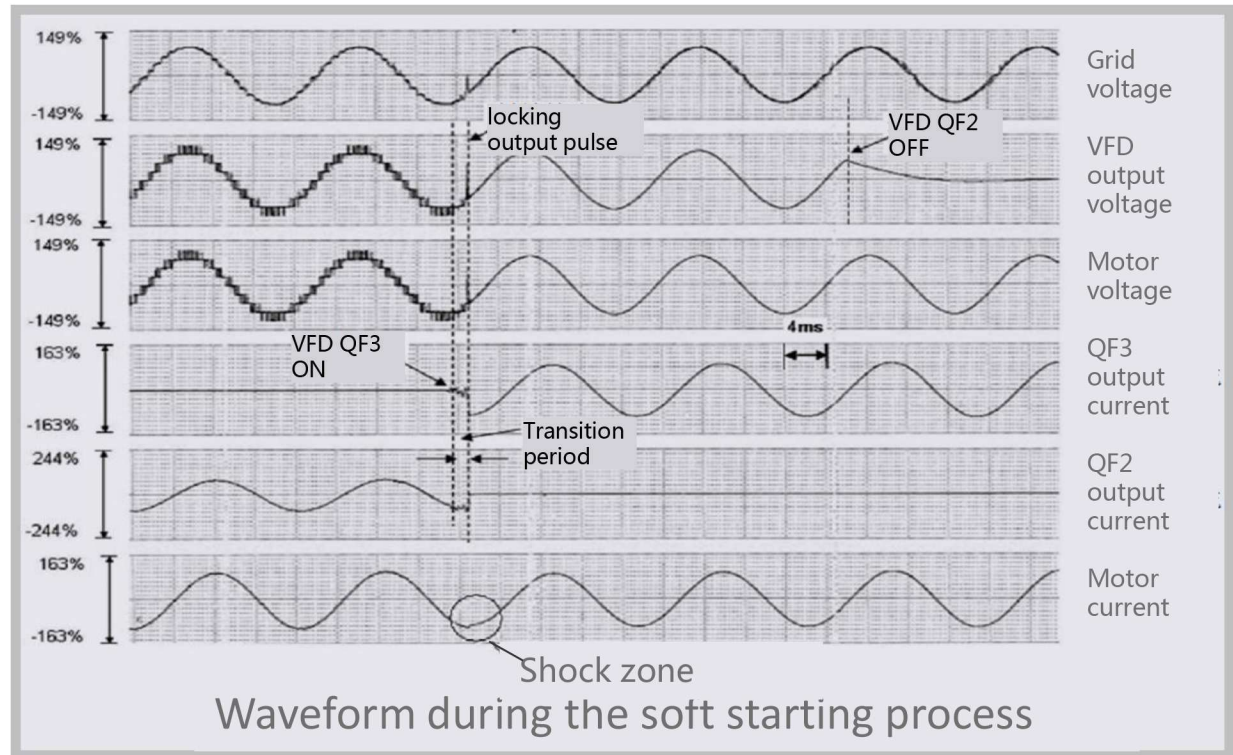
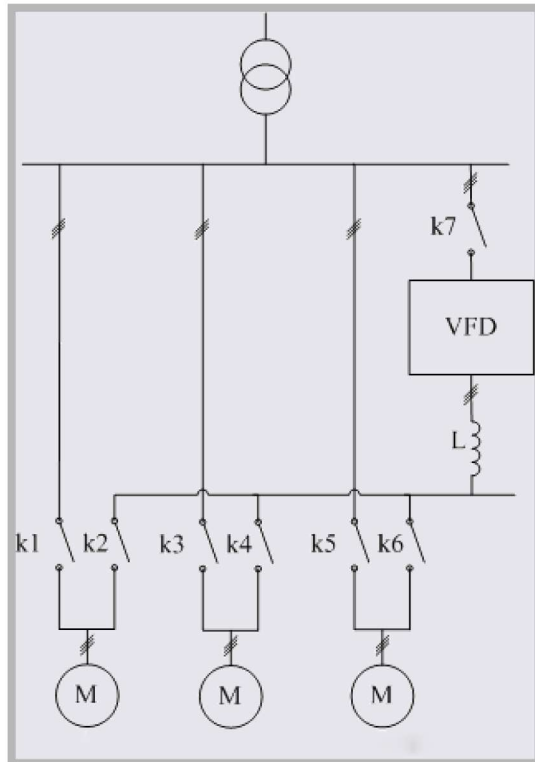

Phase-shifting Transformer



Dry-type Or Oil immersed type

Power Cell Cabinet



Control Cabinet

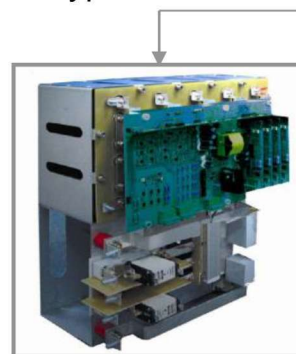

Air-cooled



Low voltage
Liquid cooled

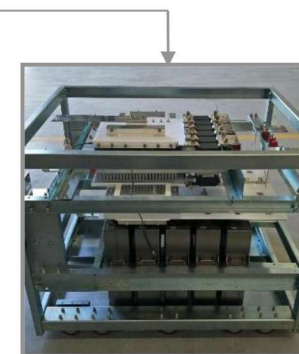

High voltage
Liquid cooled

Main
Controller

HMI

PLC

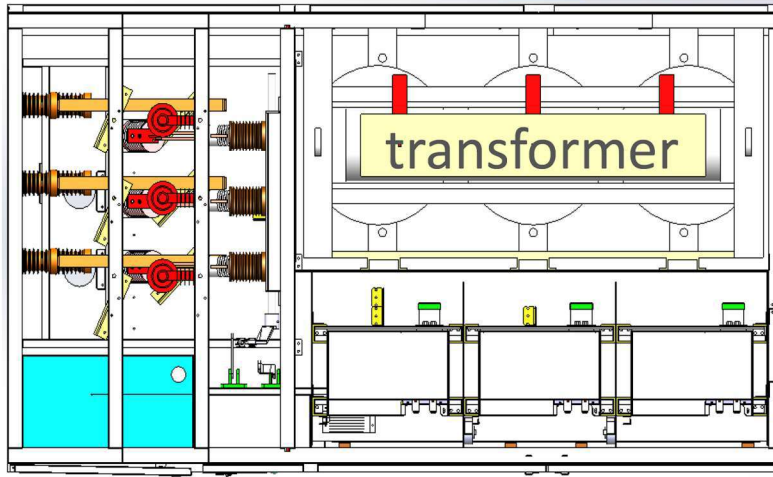

Compact size- Mini VFD

Maximum current 100A ,
1400kW@10kV, 800kW@6kV



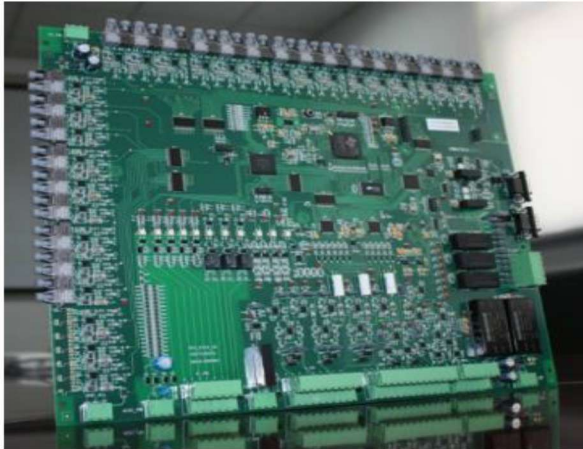

HOFFMANN
Single PCB
of six-layer

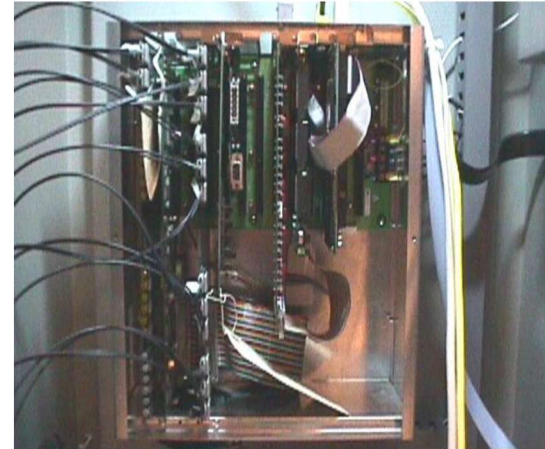

Multi pc
boards

Compared with crate type, fewer devices and better EMC performance, eliminate the possible oxidation, looseness and poor contact of the board connecting after long operation.

Reliably

Small stray inductance,
Low impedance,
Low heat loss and high reliability.

Locomotive grade oil immersed film capacitor,
with service life of 30 years.

Easy maintenance

Casters at the bottom of large power cell, lift
car provided for replacing the cell.



Large capacity water
cooled Power cell

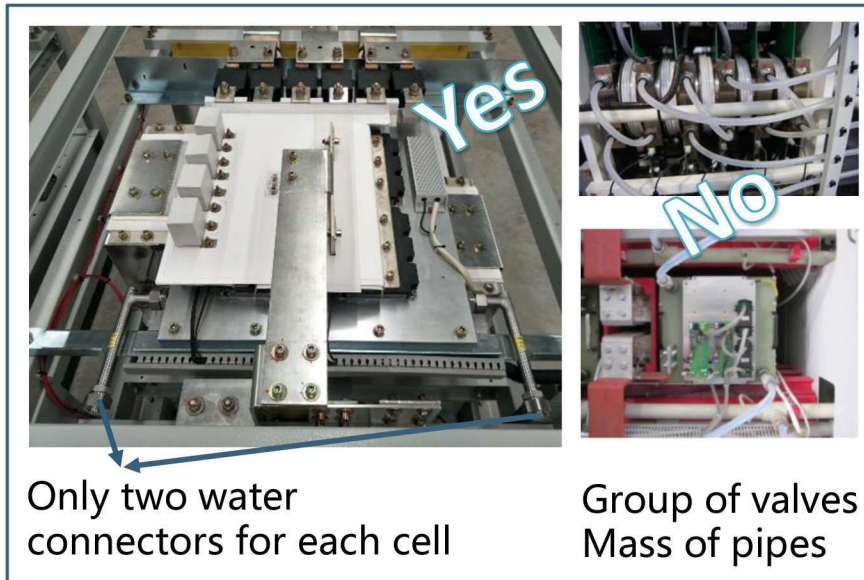

Only two water connectors for each cell

Group of valves
Mass of pipes

Large capacity water cooled Power cell

Each cell only has two water connectors: in and out ;

(in contrast to competitors, which adopt IEGT valve group structure, each semiconductor is equipped with heat sink, a large number of connecting pipes increase the probability of leakage, and the number of pipes of IEGT cell are 10 times more than HOFFMANN .

- Graphical user interface based software display real time data and waveform.
- Real time waveform display, debugging without oscilloscope.
- Fault diagnostic and historic logs.

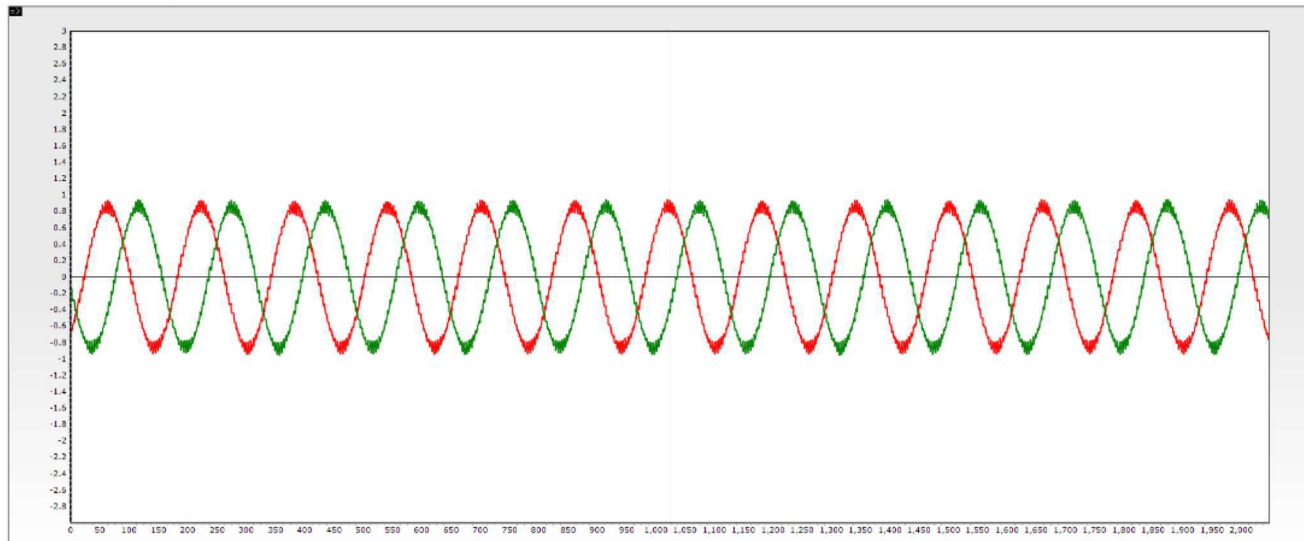

- 7-inch color touch screen, user friendly HMI.
- Fault log and event log storage.

High Performance Vector Control

Control Method	Vector control with PG / without PG / VF control
Speed Range	1000:1(with PG)/ 100:1 (without PG)
Torque Response	<3ms
Speed Accuracy	<0.02% rated speed (with PG)/<10% rated slip (without PG)

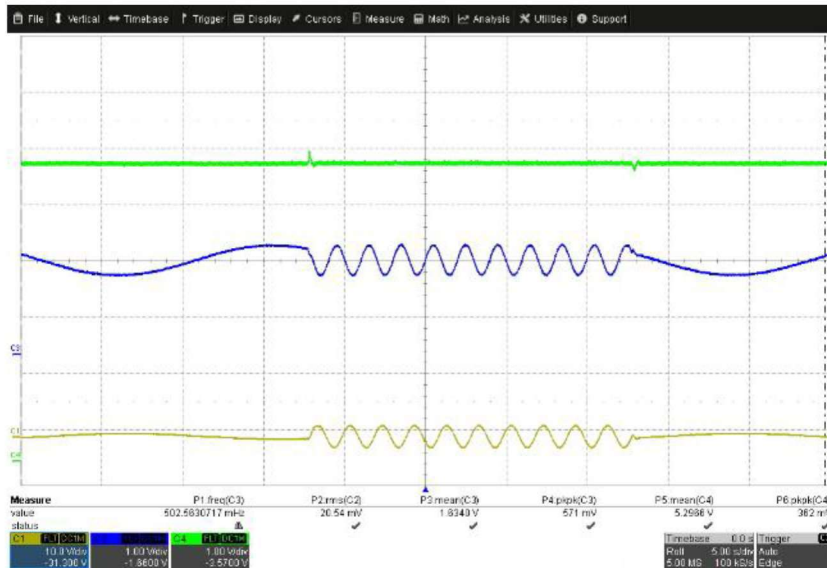

Low speed (0.05Hz—0.5Hz—0.05Hz)
Green-torque ; Blue-current ; Yellow-motor volt-second

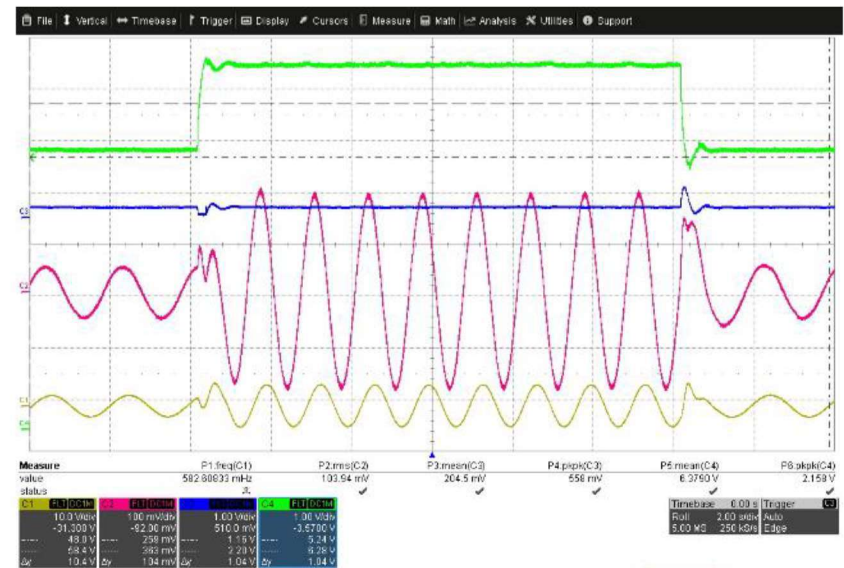

Low speed (0.5Hz) with load change
Blue-speed ; Red-current ; Yellow-motor volt-second

High Performance Vector Control

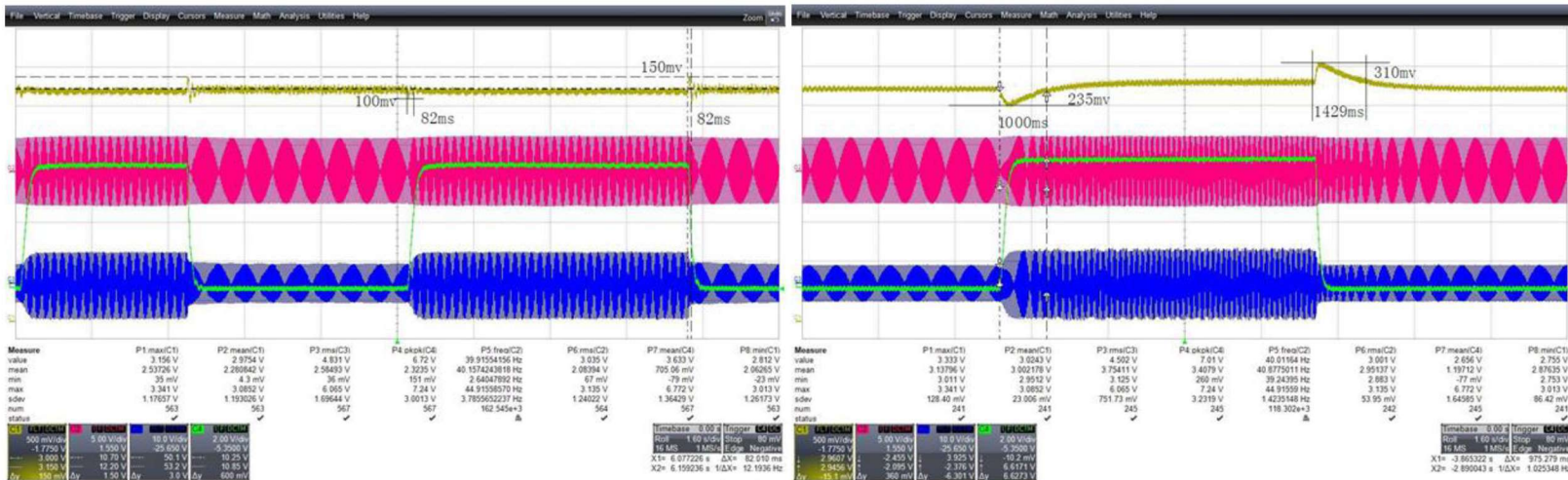

Load observer Enabled

Load Observer Disabled

Yellow-speed; Red-motor volt-second; Blue-output current; Green-torque

- Rotor flux / airgap flux orientated vector control, better dynamic performance and low speed performance;
- Encoder speed measurement adopt M/T method + 4 multiple frequency technology, high resolution and response;
- Load observer enable low fluctuation of speed at load change

Accurate control, more than “energy saving”

HOFFMANN VFD can be used for processing control.

Self-developed software has online identification and correction function, which solve motor parametric variation issues result from heating& saturation.

So compared with other competitors, HOFFMANN is “real-time” control

Help customer to save cost, without Pulse generator, the control accuracy can reach to 0.5%, which can meet most requirements.

With Pulse generator, the control accuracy can reach to 0.02%

Motor parameter auto tuning & Online identification

- Motor parameter auto tuning for control optimization;
- Motor stator resistance R_s , rotor time constant T_r online identification and correction, solve motor parametric variation issues result from motor heating/saturation.

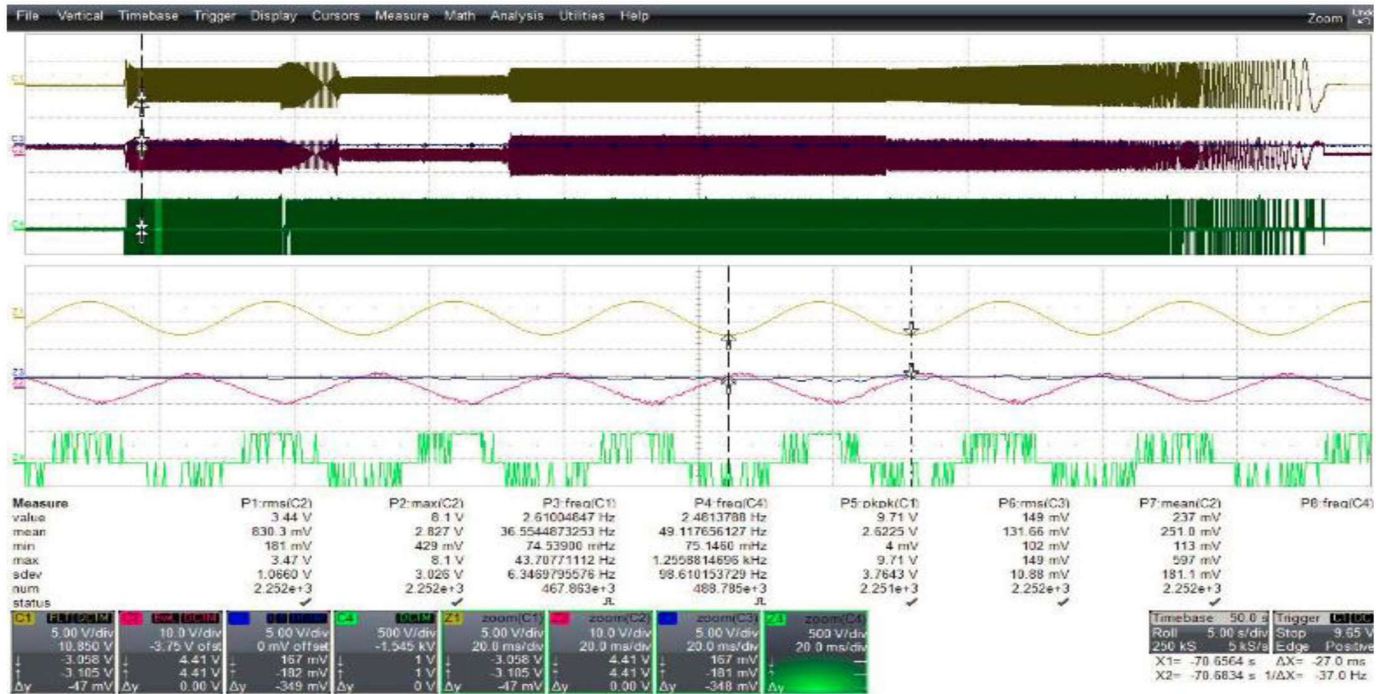

■ Green: voltage ■ Red: current

Enhanced Braking Technology

- Multiple enhanced braking technology : magnetic increased braking, DC braking and dual-frequency braking.
- Sophisticated control arithmetic, maximize the utilization of the braking torque of VFD, hence deceleration time of motor is minimized, which lower the requirement of UMD battery for the mechanical system.
- Compared with the original drive system, the deceleration time of motor could be shorten by 30%.



Dual winding motor Control

- System includes two drives with same structure, each drive have three phase output that connected to one winding of the motors respectively.
- Communication between drive A and drive B use high speed fiber-optic link, realize synchronization control.
- The maximum capacity of MVFD can be extended to 120MW.

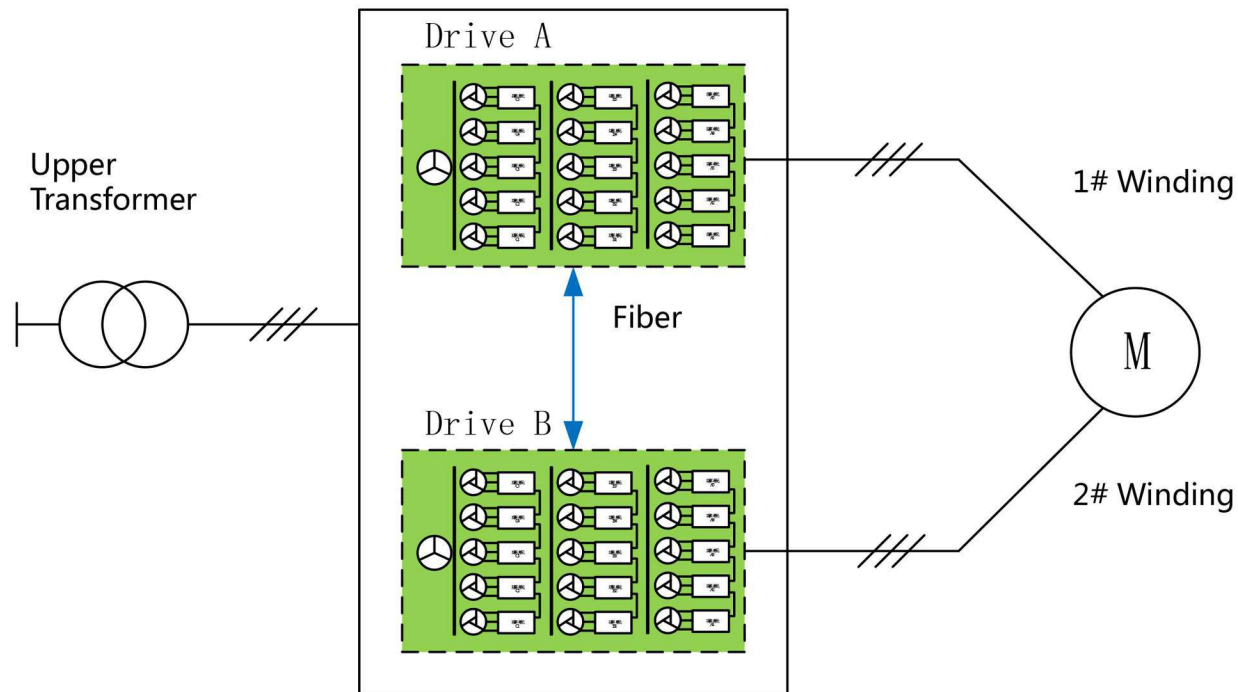



Procon—Improve Drive' s continuous Operation Performance

1 Low Voltage Ride Through

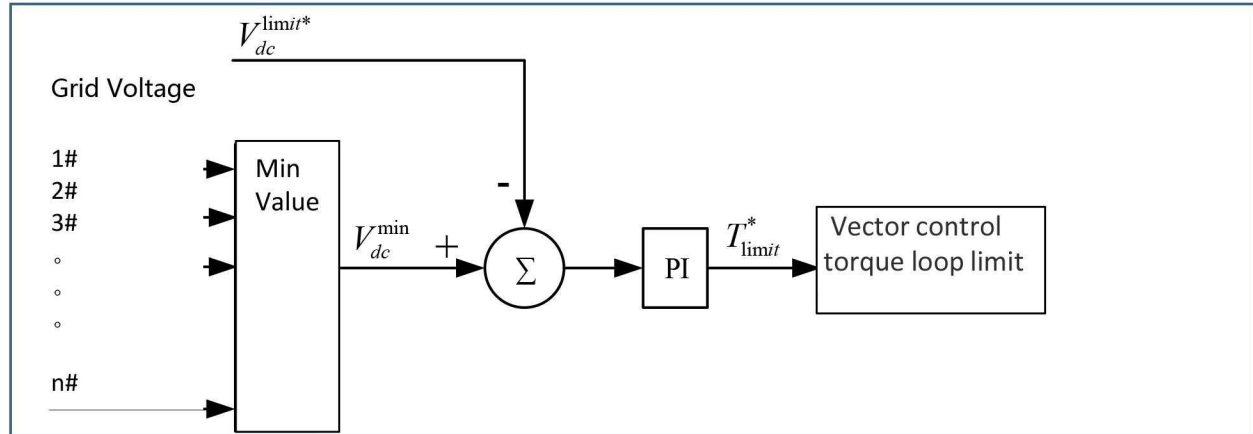

2 Dynamic spinning load pick up

3 Torque limit of quadratic load

MVFD which is equipped with ProCon could solve the problem of power supply problem at the maximum level. The equipment could be ensured to run continuously without the interference of power source and external mechanical load as much as possible.



Neutral Point Shift technology

When one power cell in one phase fails, other VFDs from our competitors will bypass the other two power cells in other two phases, so totally three power cells will be bypassed, the voltage will drop a lot.

But through our technology, we can bypass only this faulty unit, the VFD maintains a high level voltage output, ensuring that the equipment is operating normally without downtime period.



TIPM--Secondary Protection of Multiple Winding Phase-shifting Transformer

- Multiple secondary winding phase-shifting transformer is a special transformer compare with normal power transformer, the regular protection method could not protect secondary when short circuited period.
- When transformer secondary winding has short circuit, grounding or interturn short circuit, TIPM can identify the fault and protect, preventing the fault spreading and eliminate the danger.

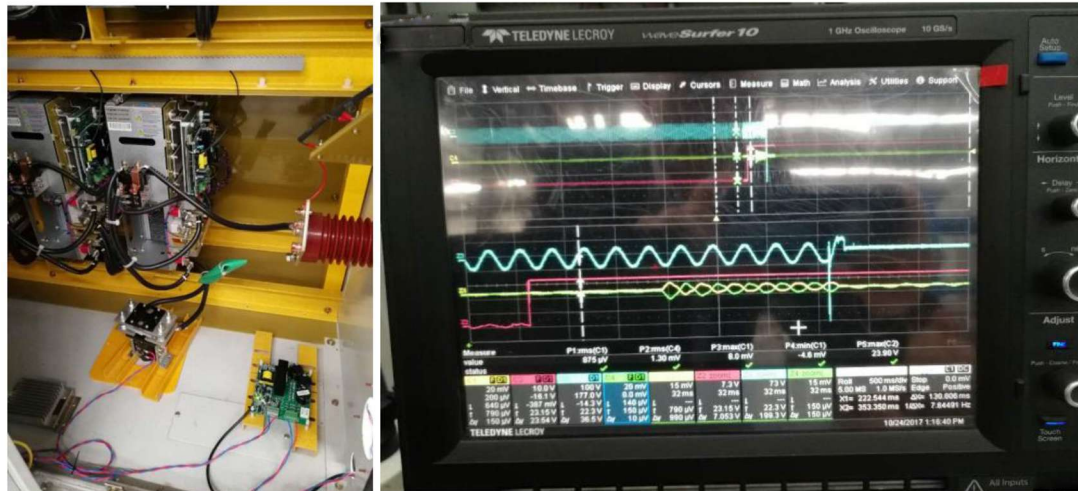



Redundancy control power & auxiliary power

HOFFMANN can get AC 220V 1Ph for control system & AC 380V 3Ph Power for fan operation from phase-shifting transformer. No need extra UPS.



VSV Technology ---VSD + SVG integrated

No extra SVG required for system which need Var compensation when motor is idle.

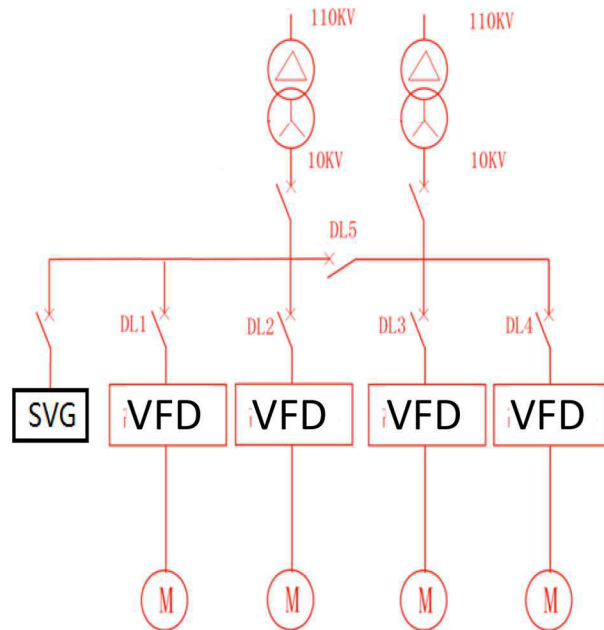

Normal solution

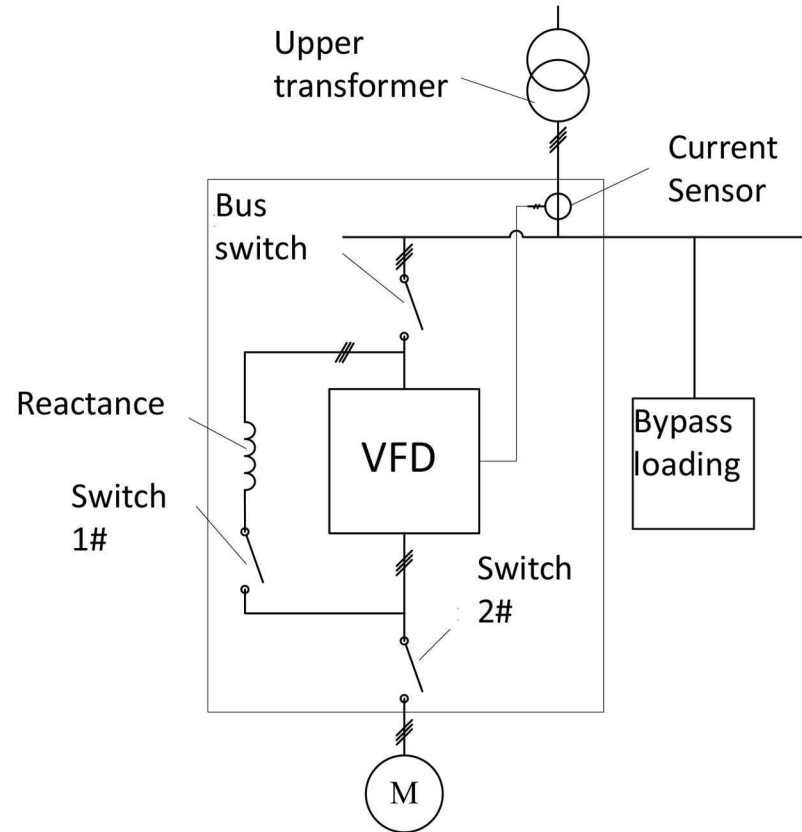

VSV solution

VSV Technology ---VSD + SVG integrated

No extra SVG required for system which need Var compensation when motor is idle.

- Low cost: base on existing VFD, only add switch, reactor & software upgrade.
- Multilevel PWM, high quality output waveform, extremely low harmonic.
- Small footprint: only add one small cabinet for switch and reactor.
- No extra maintenance cost.
- When the system changes to reactive compensation mode, the equipment is still running, no damp and freeze problem compare with VFD in idle mode.
- Reactive compensation mode is the online standby for VFD mode, and vice versa.
- Used for VFD application and asynchronous motor soft starter, no extra SVG for reactive compensation.
- Applicable for new project or retrofit.
- Standard design of the natural long-distance pipeline compressor station, lead import manufacturers, successful implementation of industry barriers to import brands.





Power Module Test

Oil-immersed
transformer Test

Isolation & Voltage
Resistance Test

Inrush Current Measurement

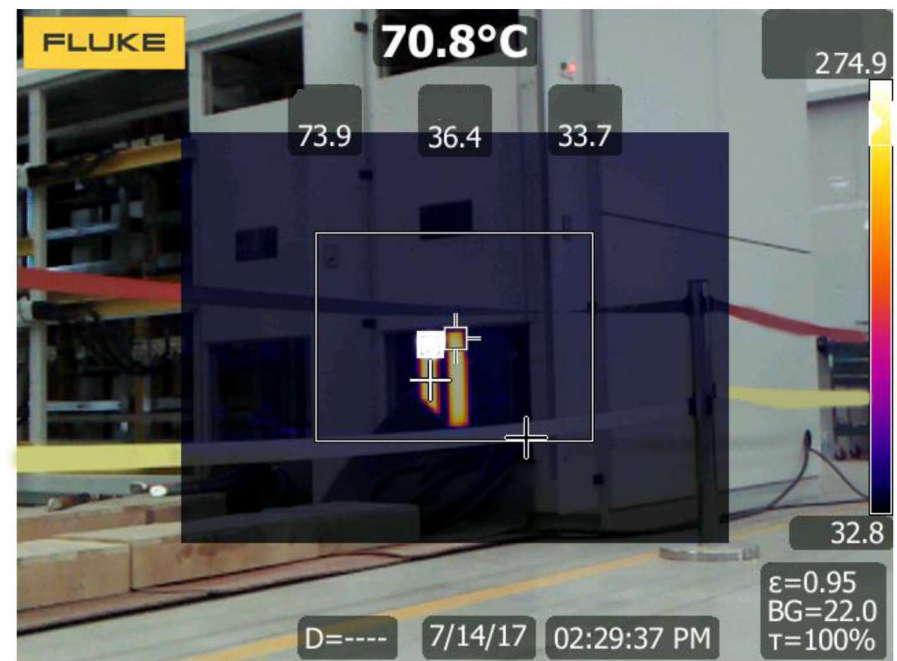
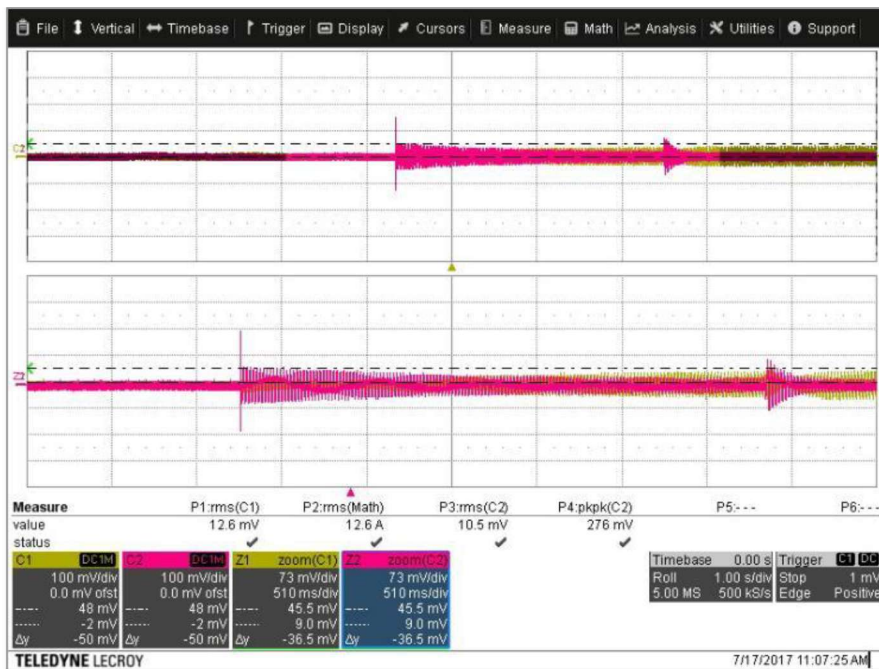

Overcurrent Protection

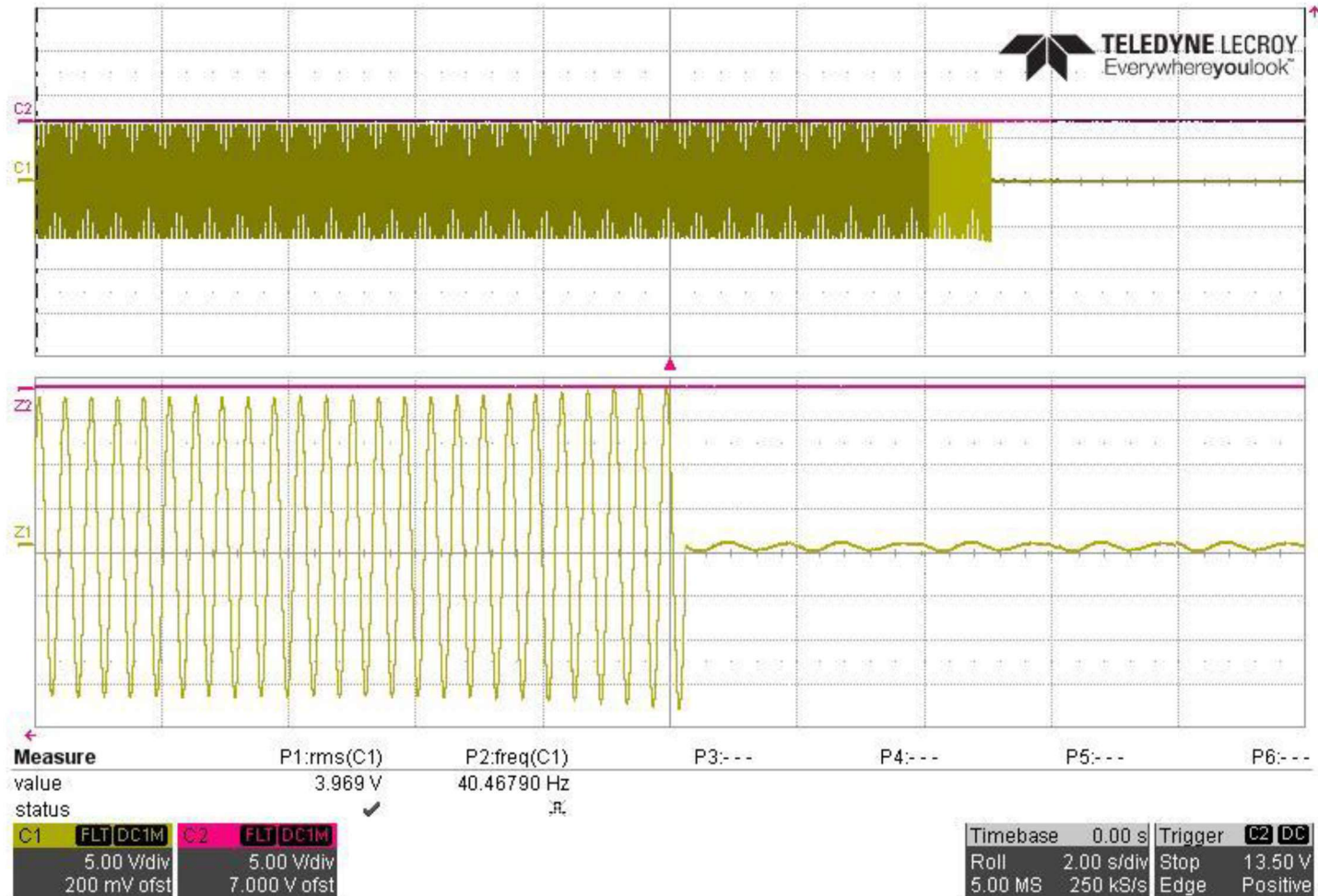

Spinning Load Pickup

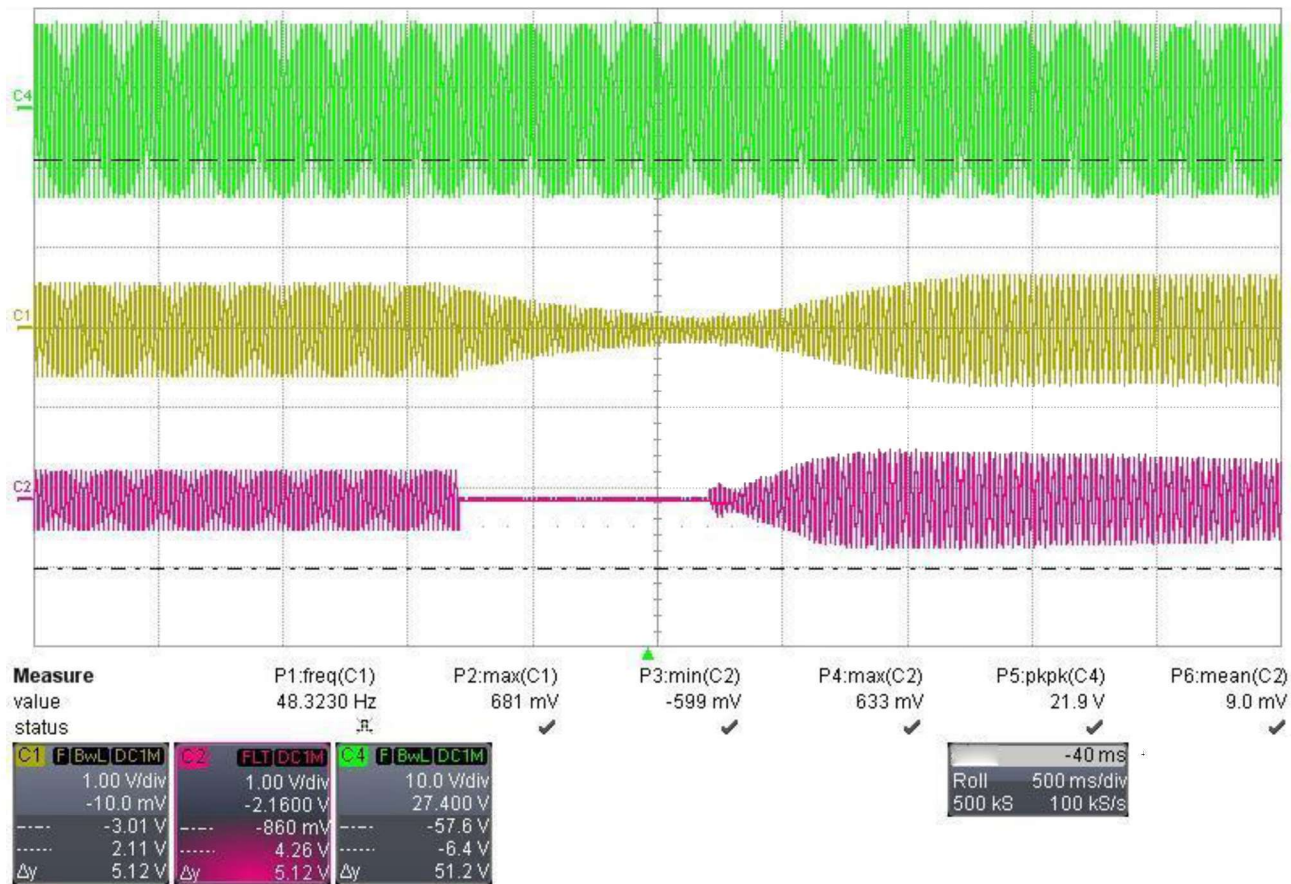

C1 (yellow) output voltage; C2 (red) output current

Full Load Test



TELEDYNE LECROY

7/18/2017 11:35:48 AM

du/dt test of high voltage module

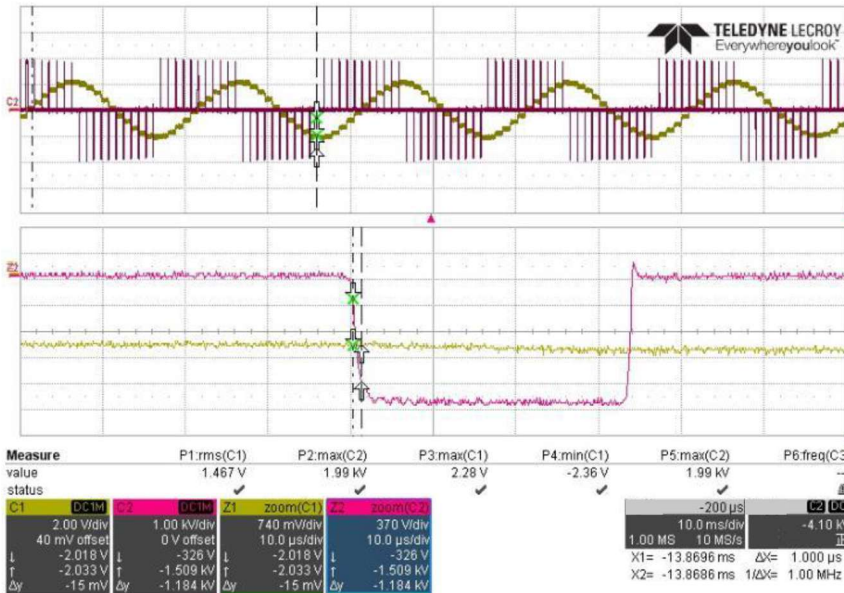

1450A RMS, at peak value

On du/dt:
1184V/1μS=1184V/μS

Note: du/dt < 900V/μS
for low voltage cell

Off du/dt: 857V/500nS=1714V/μS

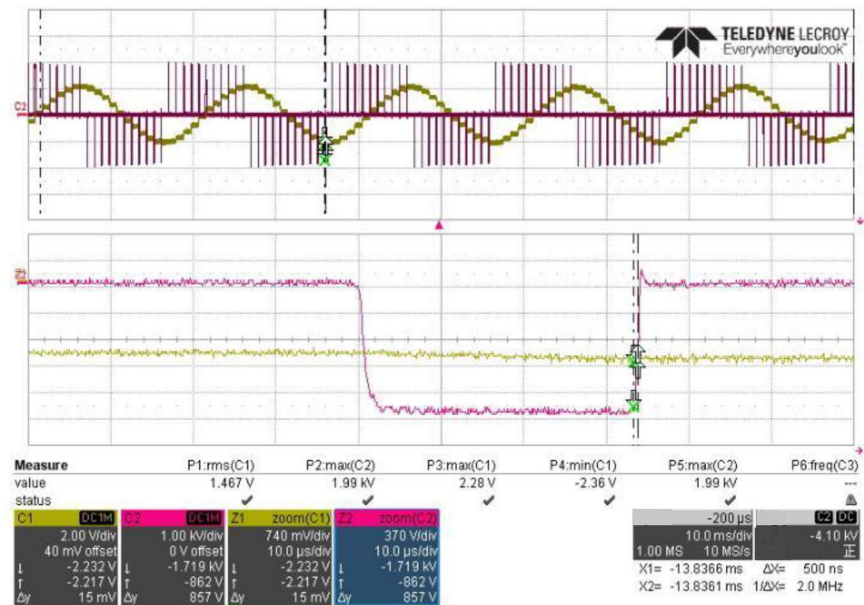

Low voltage ride through (LVRT)

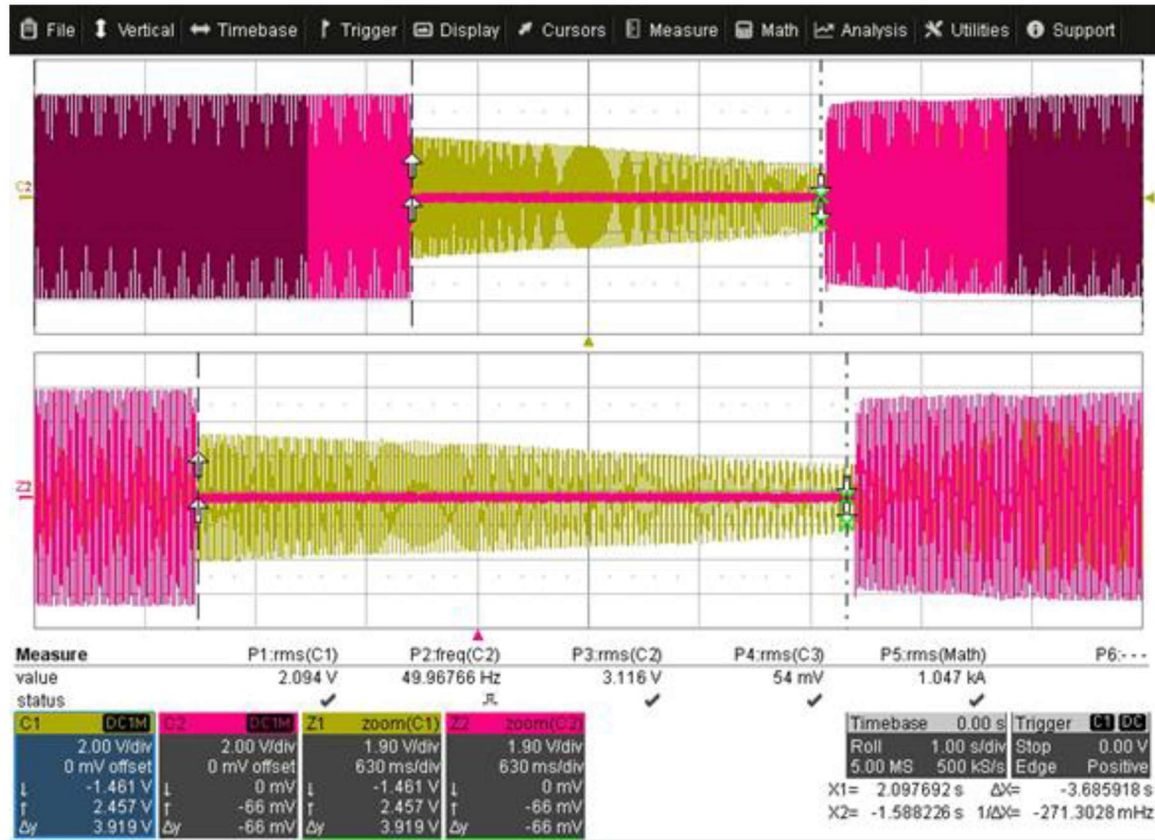

C1(yellow) output voltage
C2 (red) input voltage



- **Power plant:** induced draft fan, blower, circulating pump, condenser pump, feed water pump and mortar pump, etc.
- **Water and sewage:** water pump, sewage pump, etc.
- **Petrochemical and gas:** fan, compressor, injection pump, oil pump, electric submersible pump, etc.
- **Metallurgy:** dust removal fan, induced draft fan, blower, water pump, slurry pump, etc.
- **Coal mine:** fan, water pump, grinding machine, crusher.
- **Cement & building materials:** preheater fan, fan at kiln head, circulation fan, high temperature exhaust fan, etc.
- **Aviation equipment:** wind tunnel, compressor test stand.
- **Test stand:** transformer test, motor test.
- **Water diversion project:** large water pumps, pumped storage power station.





Thank you!