

**HOCHSPANNUNGS-DREHSTROMMOTOREN**

Kompakte Ausführung, Kühlart: IC411 Eigenbelüftet

**THREE - PHASE HIGH VOLTAGE MOTORS**

Compact Design, Cooling Method: IC411 Self-ventilated

**Moteurs triphasé a haute tension**

Design compact, Méthode de refroidissement: IC411 Autoventilés

**6.6kV - 50 Hz - CL F - IP55**

Typ	Nennleistung	Nenn-drehzahl	N-strom 6.6kV	Leistungs- faktor	Wirkungs- grad	Anzugs- moment	Anzugs- strom	Kipp- moment	Trägheits- moment	Gewicht
Type	Rated output	Rated speed	Current 6.6kV	Power factor	Efficiency %	Relative torque	Relative current	B-down Torque	Moment of inertia	Weight
Type	Puissance nominale	Vitesse nominale	Intensité 6.6kV	Facteur de puissance	Rendement %	Couple démarrage	Courant démarrage	Couple maximal	Moment d'inertie	Masse
	KW	1 / min	A	cos $\varphi$	%	MA / MN	Ia / In	MK / MN	Kg/m2	kg

**2 Polig / 2 Poles / 2 Pôles**

HJC355A-2	185	2968	19.0	0.90	94.8	0.7	7.0	2.0	2.0	2035
HJC355B-2	200	2968	20.5	0.90	95.1	0.7	7.0	2.0	2.5	2080
HJC355C-2	220	2968	22.4	0.90	95.4	0.7	7.0	2.0	2.4	2155
HJC355D-2	250	2971	25.4	0.90	95.6	0.7	7.0	2.0	2.5	2195
HJC355E-2	280	2971	28.4	0.90	95.8	0.7	7.0	2.0	2.8	2240
HJC400A-2	315	2971	32.0	0.90	95.8	0.7	7.0	2.0	4.3	2730
HJC400B-2	355	2973	36.0	0.90	95.9	0.7	7.0	2.0	4.5	2810
HJC400C-2	400	2973	40.5	0.90	96.0	0.7	7.0	2.0	4.9	2925
HJC400D-2	450	2976	45.5	0.90	96.2	0.7	7.0	2.0	5.3	3015
HJC450A-2	500	2976	50.0	0.91	96.3	0.7	7.0	2.0	6.0	3475
HJC450B-2	560	2978	56.0	0.91	96.3	0.7	7.0	2.0	6.2	3610
HJC450C-2	630	2978	63.0	0.91	96.3	0.7	7.0	2.0	6.8	3770
HJC450D-2	710	2978	70.8	0.91	96.5	0.7	7.0	2.0	7.5	3910
HJC500A-2	800	2979	79.8	0.91	96.5	0.7	7.0	2.0	15.0	5725
HJC500B-2	900	2979	89.8	0.91	96.5	0.7	7.0	2.0	16.0	5855
HJC500C-2	1000	2980	99.6	0.91	96.6	0.7	7.0	2.0	17.0	5990
HJC500D-2	1120	2980	111.4	0.91	96.8	0.7	7.0	2.0	19.0	6230
HJC560A-2	1250	2980	124.2	0.91	96.9	0.7	7.0	2.0	28.0	7475
HJC560B-2	1400	2985	137.5	0.92	96.9	0.7	7.0	2.0	30.0	7765
HJC560C-2	1600	2985	157.0	0.92	97.0	0.7	7.0	2.0	32.0	8085





## HOCHSPANNUNGS-DREHSTROMMOTOREN

Kompakte Ausführung, Kühlart: IC411 Eigenbelüftet

### THREE - PHASE HIGH VOLTAGE MOTORS

Compact Design, Cooling Method: IC411 Self-ventilated

### Moteurs triphasé a haute tension

Design compact, Méthode de refroidissement: IC411 Autoventilés



### 6.6kV - 50 Hz - CL F - IP55

Typ	Nennleistung	Nenn-drehzahl	N-strom 6.6kV	Leistungs-faktor	Wirkungs-grad	Anzugs-moment	Anzugs-strom	Kipp-moment	Trägheits-moment	Gewicht
Type	Rated output	Rated speed	Current 6.6kV	Power factor	Efficiency %	Relative torque	Relative current	B-down Torque	Moment of inertia	Weight
Type	Puissance nominale	Vitesse nominale	Intensité 6.6kV	Facteur de puissance	Rendement %	Couple démarrage	Courant démarrage	Couple maximal	Moment d'inertie	Masse
	KW	1 / min	A	cos φ	%	MA / MN	Ia / In	MK / MN	Kg/m2	kg

#### 4 Polig / 4 Poles / 4 Pôles

HJC355A-4	185	1482	20.1	0.85	94.6	0.8	6.5	2.0	4.8	2175
HJC355B-4	200	1482	21.7	0.85	94.8	0.8	6.5	2.0	5.4	2250
HJC355C-4	220	1482	23.9	0.85	95.0	0.8	6.5	2.0	5.8	2310
HJC355D-4	250	1484	27.1	0.85	95.2	0.8	6.5	2.0	6.1	2345
HJC355E-4	280	1484	30.2	0.85	95.5	0.8	6.5	2.0	6.4	2385
HJC400A-4	315	1484	34.0	0.85	95.6	0.8	6.5	2.0	8.0	2935
HJC400B-4	355	1486	38.1	0.85	95.9	0.8	6.5	2.0	8.5	3035
HJC400C-4	400	1486	42.9	0.85	96.1	0.8	6.5	2.0	9.3	3120
HJC400D-4	450	1486	47.6	0.86	96.2	0.8	6.5	2.0	9.8	3190
HJC450A-4	500	1486	52.9	0.86	96.3	0.8	6.5	2.0	13.0	3850
HJC450B-4	560	1486	59.2	0.86	96.3	0.8	6.5	2.0	15.0	4045
HJC450C-4	630	1486	66.6	0.86	96.4	0.8	6.5	2.0	16.0	4310
HJC450D-4	710	1486	74.0	0.87	96.6	0.8	6.5	2.0	18.0	4550
HJC500A-4	800	1487	83.3	0.87	96.7	0.8	6.5	2.0	33.0	5540
HJC500B-4	900	1488	93.7	0.87	96.7	0.8	6.5	2.0	35.0	5730
HJC500C-4	1000	1489	104.0	0.87	96.8	0.8	6.5	2.0	37.0	5845
HJC500D-4	1120	1489	116.4	0.87	96.9	0.8	6.5	2.0	39.0	5970
HJC560A-4	1250	1489	129.9	0.87	96.9	0.8	6.5	2.0	63.0	7575
HJC560B-4	1400	1489	142.0	0.89	97.0	0.8	6.5	2.0	68.0	7885
HJC560C-4	1600	1489	162.0	0.89	97.2	0.8	6.5	2.0	76.0	8245





## HOCHSPANNUNGS-DREHSTROMMOTOREN

Kompakte Ausführung, Kühlart: IC411 Eigenbelüftet

## THREE - PHASE HIGH VOLTAGE MOTORS

Compact Design, Cooling Method: IC411 Self-ventilated

## Moteurs triphasé a haute tension

Design compact, Méthode de refroidissement: IC411 Autoventilés



### 6.6kV - 50 Hz - CL F - IP55

Typ	Nennleistung	Nenn-drehzahl	N-strom 6.6kV	Leistungs-faktor	Wirkungs-grad	Anzugs-moment	Anzugs-strom	Kipp-moment	Trägheits-moment	Gewicht
Type	Rated output	Rated speed	Current 6.6kV	Power factor	Efficiency %	Relative torque	Relative current	B-down Torque	Moment of inertia	Weight
Type	Puissance nominale	Vitesse nominale	Intensité 6.6kV	Facteur de puissance	Rendement %	Couple démarrage	Courant démarrage	Couple maximal	Moment d'inertie	Masse

	KW	1 / min	A	cos φ	%	MA / MN	Ia / In	MK / MN	Kg/m2	kg
--	----	---------	---	-------	---	---------	---------	---------	-------	----

### 6 Polig / 6 Poles / 6 Pôles

HJC355C-6	160	987	18.3	0.81	94.4	0.8	6.5	2.0	6.5	2330
HJC355D-6	185	987	21.1	0.81	94.6	0.8	6.5	2.0	7.0	2395
HJC355E-6	200	987	22.8	0.81	94.8	0.8	6.5	2.0	7.8	2480
HJC400A-6	220	987	24.8	0.82	94.9	0.8	6.5	2.0	11.8	2950
HJC400B-6	250	987	27.7	0.83	95.4	0.8	6.5	2.0	12.5	3000
HJC400C-6	280	987	30.9	0.83	95.5	0.8	6.5	2.0	13.3	3110
HJC400D-6	315	987	34.7	0.83	95.7	0.8	6.5	2.0	14.3	3220
HJC450A-6	355	989	39.1	0.83	95.7	0.8	6.0	2.0	16.0	3960
HJC450B-6	400	989	44.1	0.83	95.7	0.8	6.0	2.0	18.0	4170
HJC450C-6	450	989	49.6	0.83	95.8	0.8	6.0	2.0	20.0	4370
HJC450D-6	500	989	55.0	0.83	96.0	0.8	6.0	2.0	22.0	4570
HJC500A-6	560	990	61.5	0.83	96.1	0.8	6.0	2.0	44.0	5725
HJC500B-6	630	990	69.1	0.83	96.2	0.8	6.0	2.0	46.0	5845
HJC500C-6	710	990	77.7	0.83	96.4	0.8	6.0	2.0	48.0	6120
HJC500D-6	800	990	87.5	0.83	96.5	0.8	6.0	2.0	51.0	6300
HJC560A-6	900	991	97.1	0.84	96.6	0.8	6.0	2.0	97.0	7350
HJC560B-6	1000	991	107.8	0.84	96.7	0.8	6.0	2.0	101.0	7620
HJC560C-6	1120	992	120.5	0.84	96.9	0.8	6.0	2.0	106.0	7840
HJC560D-6	1250	992	134.4	0.84	97.0	0.8	6.0	2.0	113.0	8095





## HOCHSPANNUNGS-DREHSTROMMOTOREN

Kompakte Ausführung, Kühlart: IC411 Eigenbelüftet

### THREE - PHASE HIGH VOLTAGE MOTORS

Compact Design, Cooling Method: IC411 Self-ventilated

### Moteurs triphasé a haute tension

Design compact, Méthode de refroidissement: IC411 Autoventilés



### 6.6kV - 50 Hz - CL F - IP55

Typ	Nennleistung	Nenn-drehzahl	N-strom 6.6kV	Leistungs-faktor	Wirkungs-grad	Anzugs-moment	Anzugs-strom	Kipp-moment	Trägheits-moment	Gewicht
Type	Rated output	Rated speed	Current 6.6kV	Power factor	Efficiency %	Relative torque	Relative current	B-down Torque	Moment of inertia	Weight
Type	Puissance nominale	Vitesse nominale	Intensité 6.6kV	Facteur de puissance	Rendement %	Couple démarrage	Courant démarrage	Couple maximal	Moment d'inertie	Masse
	KW	1 / min	A	cos $\varphi$	%	MA / MN	Ia / In	MK / MN	Kg/m2	kg

#### 8 Polig / 8 Poles / 8 Pôles

HJC400A-8	160	742	19.6	0.76	93.9	0.8	5.5	2.0	12.5	2930
HJC400B-8	185	742	22.7	0.76	94.1	0.8	5.5	2.0	13.0	2975
HJC400C-8	200	742	24.1	0.77	94.3	0.8	5.5	2.0	14.0	3085
HJC400D-8	220	742	26.5	0.77	94.5	0.8	5.5	2.0	15.3	3205
HJC450A-8	250	742	29.6	0.78	94.7	0.8	5.5	2.0	16.0	3955
HJC450B-8	280	742	33.2	0.78	94.8	0.8	5.5	2.0	18.0	4155
HJC450C-8	315	742	37.2	0.78	95.0	0.8	5.5	2.0	20.0	4355
HJC450D-8	355	742	41.9	0.78	95.1	0.8	5.5	2.0	22.0	4560
HJC500A-8	400	743	46.0	0.80	95.3	0.8	5.5	2.0	44.0	5720
HJC500B-8	450	743	51.5	0.80	95.6	0.8	5.5	2.0	46.0	5840
HJC500C-8	500	743	57.2	0.80	95.7	0.8	5.5	2.0	48.0	6110
HJC500D-8	560	743	64.0	0.80	95.8	0.8	5.5	2.0	51.0	6290
HJC560A-8	630	745	71.0	0.81	95.9	0.8	5.5	2.0	120.0	6860
HJC560B-8	710	745	80.1	0.81	95.9	0.8	5.5	2.0	128.0	7145
HJC560C-8	800	745	90.0	0.81	96.1	0.8	5.5	2.0	134.0	7370
HJC560D-8	900	745	101.2	0.81	96.2	0.8	5.5	2.0	140.0	7610



Overall mounting dimensions for HJC (6.6kV) series of high-voltage three-phase induction motors. Compact Design

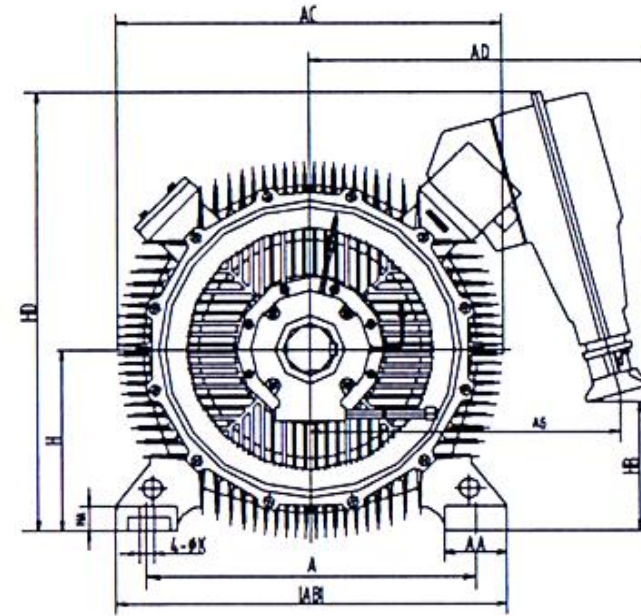
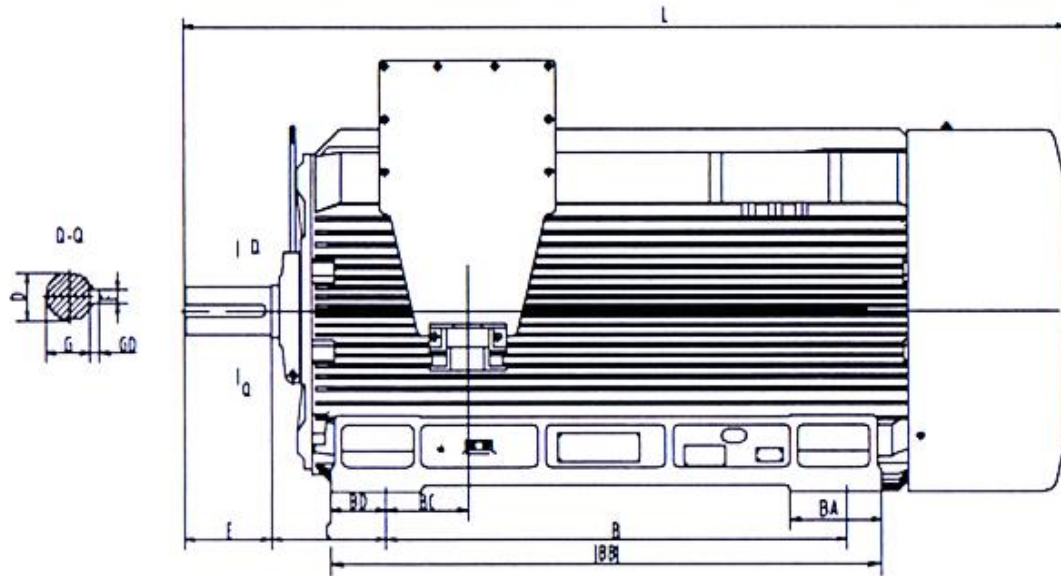

Frame Size	No of poles	Mounting dimension and tolerance									Overall dimension													
		A	B	C	D	E	F	G	H	K	AA	AB	AC	AD	AG	BA	BB	BC	BD	GD	H	HB	HD	L
HJC-355	2	630	900	254	75	140	20	67.5	355	28	160	790	750	780	730	240	1110	217	112	14	50	210	1010	1770
HJC-355	4-6	630	900	254	100	210	28	90	355	28	160	790	750	780	730	240	1110	217	112	16	50	210	1010	1840
HJC-400	2	710	1000	280	85	170	22	76	400	35	160	870	840	830	745	240	1200	200	115	14	50	335	1110	1900
HJC-400	4-8	710	1000	280	110	210	28	100	400	35	160	870	840	830	745	240	1200	200	115	16	50	335	1110	2000
HJC-450	2	800	1120	280	95	170	25	86	450	35	160	950	910	855	790	240	1340	165	136	14	50	370	1170	2070
HJC-450	4	800	1120	280	120	210	32	109	450	35	160	950	910	855	790	240	1340	165	136	18	50	370	1170	2150
HJC-450	6-8	800	1120	280	130	250	32	119	450	35	160	950	910	855	790	240	1340	165	136	18	50	370	1170	2250
HJC-500	2	900	1250	425	110	210	28	100	500	42	200	1080	1035	910	820	300	1490	264	114	16	50	490	1290	2580
HJC-500	4	900	1250	315	130	250	32	119	500	42	200	1080	1035	910	820	300	1490	264	114	18	50	490	1290	2380
HJC-500	6-8	900	1250	315	140	250	36	128	500	42	200	1080	1035	910	820	300	1490	264	114	20	50	490	1290	2485
HJC-560	2	1000	1400	530	130	250	32	119	560	42	210	1170	1185	955	870	300	1680	178	170	18	60	595	1400	2900
HJC-560	4	1000	1400	355	150	250	36	138	560	42	210	1170	1185	955	870	300	1680	178	170	20	60	595	1400	2600
HJC-560	6-8	1000	1400	355	160	300	4	147	560	42	210	1170	1185	955	870	300	1680	178	170	22	60	595	1400	2775