



HOCHSPANNUNGS-DREHSTROMMOTOREN

Kompakte Ausführung, Kühlart: IC411 Eigenbelüftet

THREE - PHASE HIGH VOLTAGE MOTORS

Compact Design, Cooling Method: IC411 Self-ventilated

Moteurs triphasé a haute tension

Design compact, Méthode de refroidissement: IC411 Autoventilés



11kV - 50 Hz - CL F - IP55

Typ	Nennleistung	Nenn-drehzahl	N-strom 11kV	Leistungs-faktor	Wirkungs-grad	Anzugs-moment	Anzugs-strom	Kipp-moment	Trägheits-moment	Gewicht
Type	Rated output	Rated speed	Current 11kV	Power factor	Efficiency %	Relative torque	Relative current	B-down Torque	Moment of inertia	Weight
Type	Puissance nominale	Vitesse nominale	Intensité 11kV	Facteur de puissance	Rendement %	Couple démarrage	Courant démarrage	Couple maximal	Moment d'inertie	Masse
	KW	1 / min	A	cos φ	%	MA / MN	Ia / In	MK / MN	Kg/m2	kg

2 Polig / 2 Poles / 2 Pôles

HJC450A-2	220	2973	14.5	0.84	94.6	0.7	7.0	2.0	5.6	2875
HJC450B-2	250	2973	16.5	0.84	94.7	0.7	7.0	2.0	6.5	3015
HJC450C-2	280	2973	18.0	0.86	94.9	0.7	7.0	2.0	7.4	3155
HJC450D-2	315	2973	20.2	0.86	95.1	0.7	7.0	2.0	8.6	3315
HJC450E-2	355	2973	22.8	0.86	95.2	0.7	7.0	2.0	9.1	3400
HJC450F-2	400	2973	25.6	0.86	95.5	0.7	7.0	2.0	9.7	3480
HJC450G-2	450	2973	28.8	0.86	95.6	0.7	7.0	2.0	10.2	3525
HJC450H-2	500	2975	31.6	0.87	95.7	0.7	7.0	2.0	10.8	3615
HJC500A-2	560	2975	35.3	0.87	95.8	0.7	7.0	2.0	12.0	4970
HJC500B-2	630	2976	39.7	0.87	95.9	0.7	7.0	2.0	14.0	5090
HJC500C-2	710	2976	44.7	0.87	96.0	0.7	7.0	2.0	15.0	5220
HJC500D-2	800	2978	49.7	0.88	96.1	0.7	7.0	2.0	16.0	5330
HJC500E-2	900	2978	55.9	0.88	96.2	0.7	7.0	2.0	17.0	5460
HJC560A-2	1000	2980	62.0	0.88	96.3	0.7	7.0	2.0	19.0	6860
HJC560B-2	1120	2980	68.6	0.89	96.4	0.7	7.0	2.0	28.0	7160
HJC560C-2	1250	2980	76.5	0.89	96.5	0.7	7.0	2.0	30.0	7495
HJC560D-2	1400	2983	85.6	0.89	96.6	0.7	7.0	2.0	32.0	7795





HOCHSPANNUNGS-DREHSTROMMOTOREN

Kompakte Ausführung, Kühlart: IC411 Eigenbelüftet

THREE - PHASE HIGH VOLTAGE MOTORS

Compact Design, Cooling Method: IC411 Self-ventilated

Moteurs triphasé a haute tension

Design compact, Méthode de refroidissement: IC411 Autoventilés



11kV - 50 Hz - CL F - IP55

Typ	Nennleistung	Nenn-drehzahl	N-strom 11kV	Leistungs-faktor	Wirkungs-grad	Anzugs-moment	Anzugs-strom	Kipp-moment	Trägheits-moment	Gewicht
Type	Rated output	Rated speed	Current 11kV	Power factor	Efficiency %	Relative torque	Relative current	B-down Torque	Moment of inertia	Weight
Type	Puissance nominale	Vitesse nominale	Intensité 11kV	Facteur de puissance	Rendement %	Couple démarrage	Courant démarrage	Couple maximal	Moment d'inertie	Masse
	KW	1 / min	A	cos φ	%	MA / MN	Ia / In	MK / MN	Kg/m ²	kg

4 Polig / 4 Poles / 4 Pôles

HJC450A-4	220	1486	14.5	0.84	94.6	0.8	6.5	2.0	12.9	3025
HJC450B-4	250	1486	16.5	0.84	94.7	0.8	6.5	2.0	14.8	3150
HJC450C-4	280	1486	18.5	0.84	94.9	0.8	6.5	2.0	16.9	3305
HJC450D-4	315	1487	20.5	0.85	95.1	0.8	6.5	2.0	19.2	3455
HJC450E-4	355	1487	23.1	0.85	95.2	0.8	6.5	2.0	20.3	3525
HJC450F-4	400	1487	25.9	0.85	95.5	0.8	6.5	2.0	21.6	3570
HJC450G-4	450	1487	29.1	0.85	95.6	0.8	6.5	2.0	22.5	3645
HJC450H-4	500	1487	46.5	0.86	65.7	0.8	6.5	2.0	23.6	3730
HJC500A-4	560	1488	52.0	0.86	65.8	0.8	6.5	2.0	31.0	5045
HJC500B-4	630	1488	40.1	0.86	95.9	0.8	6.5	2.0	33.0	5205
HJC500C-4	710	1488	45.2	0.86	96.0	0.8	6.5	2.0	35.0	5305
HJC500D-4	800	1488	50.3	0.87	96.1	0.8	6.5	2.0	37.0	5450
HJC500E-4	900	1489	56.5	0.87	96.2	0.8	6.5	2.0	39.0	5565
HJC560A-4	1000	1489	62.7	0.87	96.3	0.7	6.5	2.0	58.0	6725
HJC560B-4	1120	1489	69.4	0.88	96.4	0.7	6.5	2.0	63.0	7020
HJC560C-4	1250	1489	77.4	0.88	96.5	0.7	6.5	2.0	68.0	7315
HJC560D-4	1400	1489	86.5	0.88	96.6	0.7	6.5	2.0	76.0	7710





HOCHSPANNUNGS-DREHSTROMMOTOREN

Kompakte Ausführung, Kühlart: IC411 Eigenbelüftet

THREE - PHASE HIGH VOLTAGE MOTORS

Compact Design, Cooling Method: IC411 Self-ventilated

Moteurs triphasé a haute tension

Design compact, Méthode de refroidissement: IC411 Autoventilés



11kV - 50 Hz - CL F - IP55

Typ	Nennleistung	Nenn-drehzahl	N-strom 11kV	Leistungs-faktor	Wirkungs-grad	Anzugs-moment	Anzugs-strom	Kipp-moment	Trägheits-moment	Gewicht
Type	Rated output	Rated speed	Current 11kV	Power factor	Efficiency %	Relative torque	Relative current	B-down Torque	Moment of inertia	Weight
Type	Puissance nominale	Vitesse nominale	Intensité 11kV	Facteur de puissance	Rendement %	Couple démarrage	Courant démarrage	Couple maximal	Moment d'inertie	Masse
	KW	1 / min	A	cos φ	%	MA / MN	Ia / In	MK / MN	Kg/m2	kg

6 Polig / 6 Poles / 6 Pôles

HJC450D-6	220	987	15.0	0.82	94.2	0.8	6.0	2.0	27.4	3500
HJC450E-6	250	987	17.0	0.82	94.3	0.8	6.0	2.0	28.8	3565
HJC450F-6	280	987	19.0	0.82	94.5	0.8	6.0	2.0	30.2	3645
HJC450G-6	315	989	21.3	0.82	94.7	0.8	6.0	2.0	33.0	3795
HJC450H-6	355	989	24.0	0.82	94.9	0.8	6.0	2.0	34.9	3900
HJC500A-6	400	990	27.0	0.82	95.0	0.8	6.0	2.0	43.0	5090
HJC500B-6	450	990	30.0	0.83	95.1	0.8	6.0	2.0	44.0	5240
HJC500C-6	500	990	33.3	0.83	95.2	0.8	6.0	2.0	46.0	5350
HJC500D-6	560	990	37.1	0.83	95.5	0.8	6.0	2.0	48.0	5495
HJC500E-6	630	990	41.7	0.83	95.6	0.8	6.0	2.0	51.0	5635
HJC560A-6	710	991	47.0	0.83	95.7	0.7	6.0	2.0	93.0	6950
HJC560B-6	800	991	52.9	0.83	95.8	0.7	6.0	2.0	97.0	7220
HJC560C-6	900	992	58.6	0.84	96.0	0.7	6.0	2.0	101.0	7495
HJC560D-6	1000	992	65.1	0.84	96.1	0.7	6.0	2.0	106.0	7740
HJC560E-6	1120	992	72.8	0.84	96.2	0.7	6.0	2.0	113.0	8010





HOCHSPANNUNGS-DREHSTROMMOTOREN

Kompakte Ausführung, Kühlart: IC411 Eigenbelüftet

THREE - PHASE HIGH VOLTAGE MOTORS

Compact Design, Cooling Method: IC411 Self-ventilated

Moteurs triphasé a haute tension

Design compact, Méthode de refroidissement: IC411 Autoventilés



11kV - 50 Hz - CL F - IP55

Typ	Nennleistung	Nenn-drehzahl	N-strom 11kV	Leistungs-faktor	Wirkungs-grad	Anzugs-moment	Anzugs-strom	Kipp-moment	Trägheits-moment	Gewicht
Type	Rated output	Rated speed	Current 11kV	Power factor	Efficiency %	Relative torque	Relative current	B-down Torque	Moment of inertia	Weight
Type	Puissance nominale	Vitesse nominale	Intensité 11kV	Facteur de puissance	Rendement %	Couple démarrage	Courant démarrage	Couple maximal	Moment d'inertie	Masse
	KW	1 / min	A	cos φ	%	MA / MN	Ia / In	MK / MN	Kg/m ²	kg

8 Polig / 8 Poles / 8 Pôles

HJC450F-8	220	742	16.0	0.77	94.1	0.8	5.5	2.0	30.0	3635
HJC450G-8	250	742	17.9	0.78	94.2	0.8	5.5	2.0	33.0	3770
HJC450H-8	280	742	20.0	0.78	94.3	0.8	5.5	2.0	35.0	3890
HJC500B-8	315	743	22.5	0.78	94.4	0.8	5.5	2.0	43.0	5150
HJC500C-8	355	743	25.3	0.78	94.6	0.8	5.5	2.0	44.0	5295
HJC500D-8	400	743	28.1	0.79	94.7	0.8	5.5	2.0	46.0	5405
HJC500E-8	450	743	31.6	0.79	94.8	0.8	5.5	2.0	48.0	5575
HJC560A-8	500	744	35.0	0.79	95.0	0.7	5.5	2.0	113.0	6525
HJC560B-8	560	744	38.7	0.80	95.1	0.7	5.5	2.0	120.0	6760
HJC560C-8	630	746	43.4	0.80	95.3	0.7	5.5	2.0	128.0	7005
HJC560D-8	710	746	48.2	0.81	95.5	0.7	5.5	2.0	134.0	7230
HJC560E-8	800	746	54.3	0.81	95.6	0.7	5.5	2.0	140.0	7470

Overall mounting dimensions for HJC (11kV) series of high-voltage three-phase induction motors. Compact Design

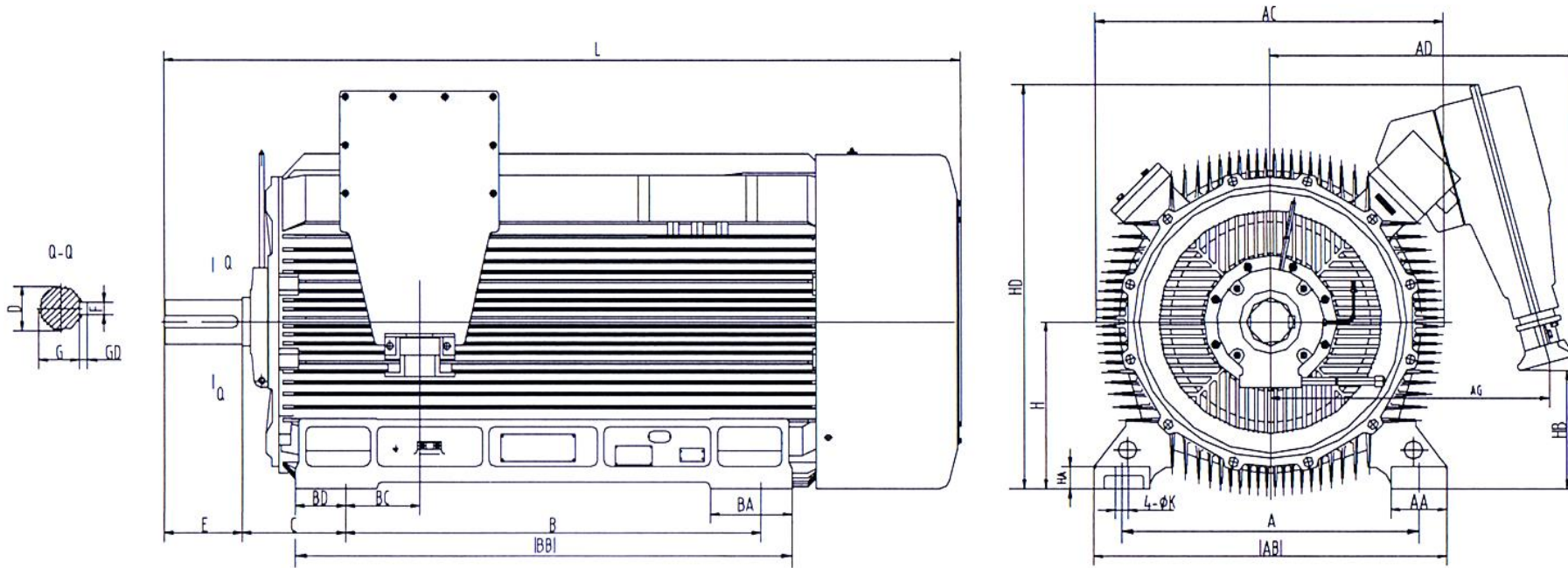

Frame Size	No of poles	Mounting dimension and tolerance									Overall dimension													
		A	B	C	D	E	F	G	H	K	AA	AB	AC	AD	AG	BA	BB	BC	BD	GD	H	HB	HD	L
HJC-450	2	800	1120	280	95	170	25	86	450	35	160	950	910	855	805	240	1340	165	136	14	50	385	1170	2070
HJC-450	4	800	1120	280	120	210	32	109	450	35	160	950	910	855	805	240	1340	165	136	18	50	385	1170	2150
HJC-450	6-8	800	1120	280	130	250	32	119	450	35	160	950	910	855	805	240	1340	165	136	18	50	385	1170	2250
HJC-500	2	900	1250	315	100	210	28	90	500	42	200	1080	1031	910	835	300	1490	264	114	16	50	490	1290	2580
HJC-500	4	900	1250	315	130	250	32	119	500	42	200	1080	1031	910	835	300	1490	264	114	18	50	490	1290	2380
HJC-500	6-8	900	1250	315	140	250	36	128	500	42	200	1080	1031	910	835	300	1490	264	114	20	50	490	1290	2480
HJC-560	2	1000	1400	530	130	250	32	119	560	42	210	1170	1185	955	890	300	1680	178	170	18	60	595	1400	2900
HJC-560	4	1000	1400	355	150	250	36	138	560	42	210	1170	1185	955	890	300	1680	178	170	20	60	595	1400	2600
HJC-560	6-8	1000	1400	355	160	300	40	147	560	42	210	1170	1185	955	890	300	1680	178	170	22	60	595	1400	2775